

Connaître son appareil numérique

François SCORSONELLI

CNAV - "Année de réalisation ou de
mise à jour"

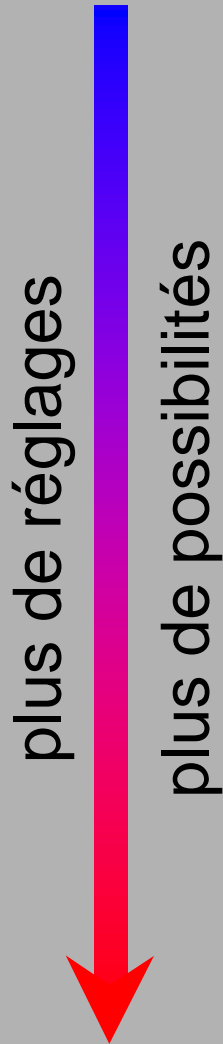

Compact (photoscope)

- Objectif fixe (mais zoom)
- Visée directe ou sur écran

Bridge (pont)

- C'est un hybride des deux
- Visée reflexe électronique

Reflex

- Objectif interchangeable
- Visée reflexe optique

important

- Les batteries
- Les cartes

exemples de cartes mémoire



CF (Compact Flash)



XD



MS (Memory Stick)



SD

Attention à la vitesse d'écriture

Le poisson n'attendra pas la carte !

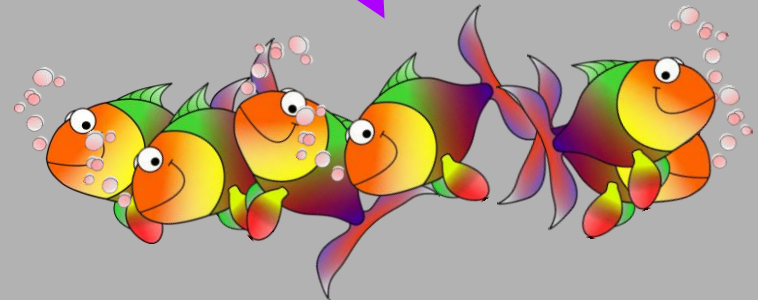
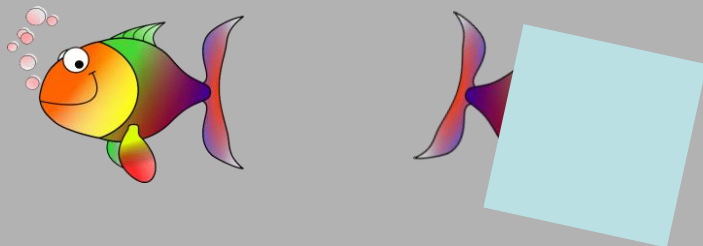

Lisez la notice
Et faites le tour
de votre APN



3 trappes



batterie



connecteurs



carte

1 à 3 affichages



dos



sommet



visueur

Les réglages essentiels

Qualité de sortie

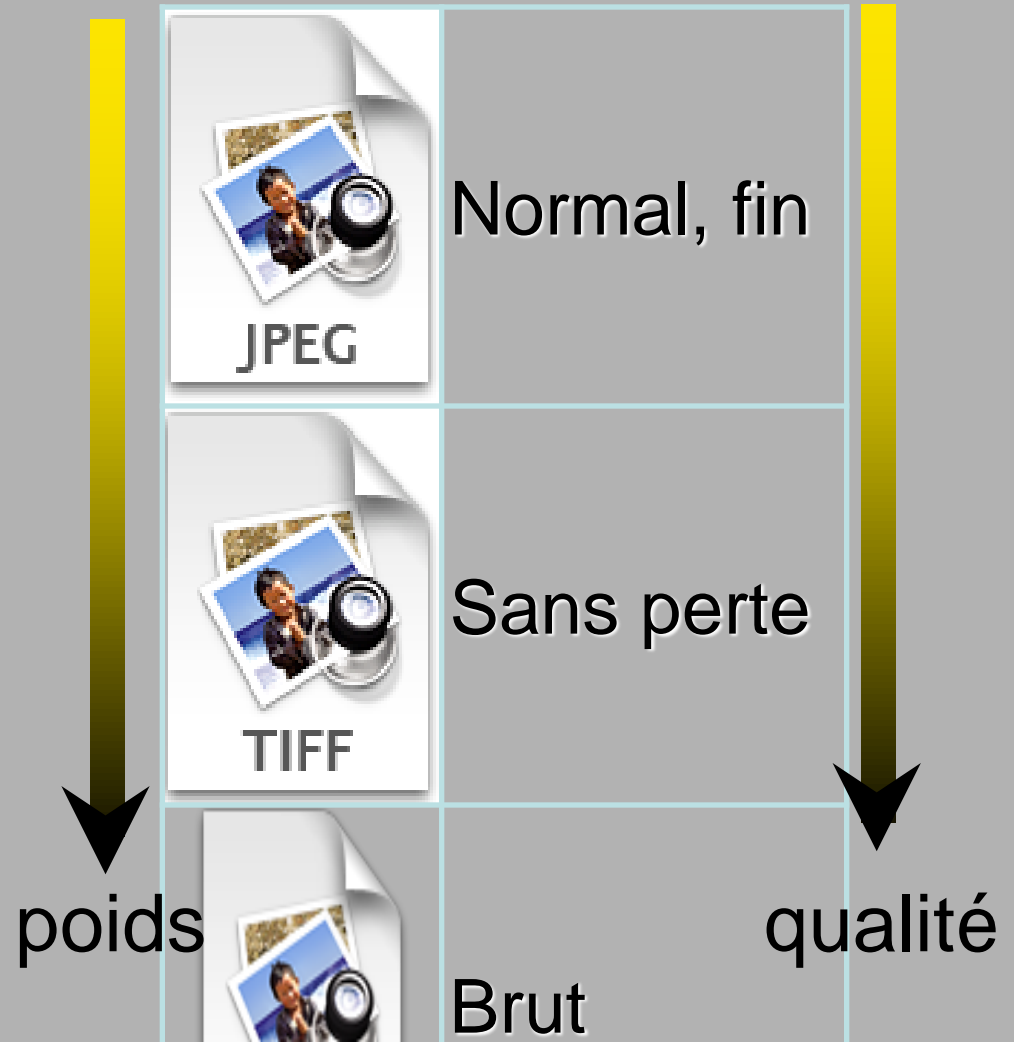

Sensibilité (ISO)



100

400

800

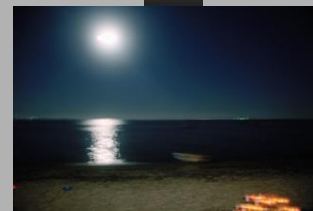

Balance des blancs (WB)



AWB

AUTO



LUMIÈRE DU JOUR



SOLEIL VOILÉ



OMBRE



TUNGSTÈNE



FLUO



FLASH

terrestre



MANUEL (3200 à 4800°K)

4 modes d'exposition



M(manuel) le photographe fait tout

P(rogram) l'appareil fait tout

S(peed)

le photographe choisit la vitesse

T(ime)

l'appareil calcule le diaphragme



A(perture)

le photographe choisit le diaphragme

l'appareil calcule la vitesse

Autres fonctions

- Activer le « verre quadrillé » qui vous servira pour la composition de l'image

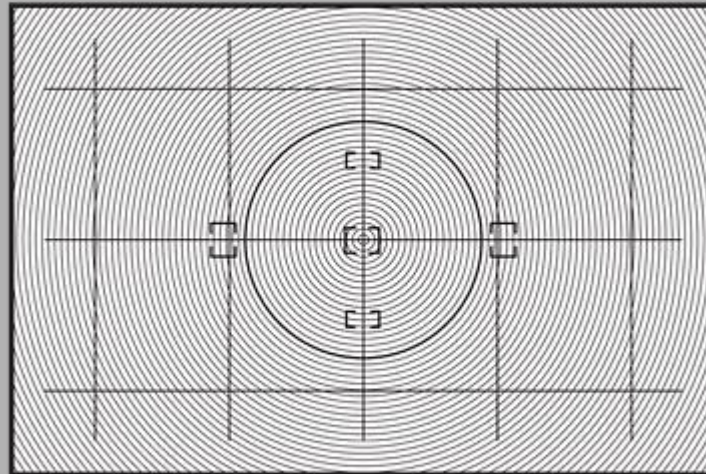

Définition

- Capteur
 - C'est le support qui permet de recevoir les données de la photo
- Diaphragme
 - C'est l'ouverture qui permet à la lumière d'entrer pour imprimer le capteur
- Vitesse
 - C'est le temps d'allumage du capteur

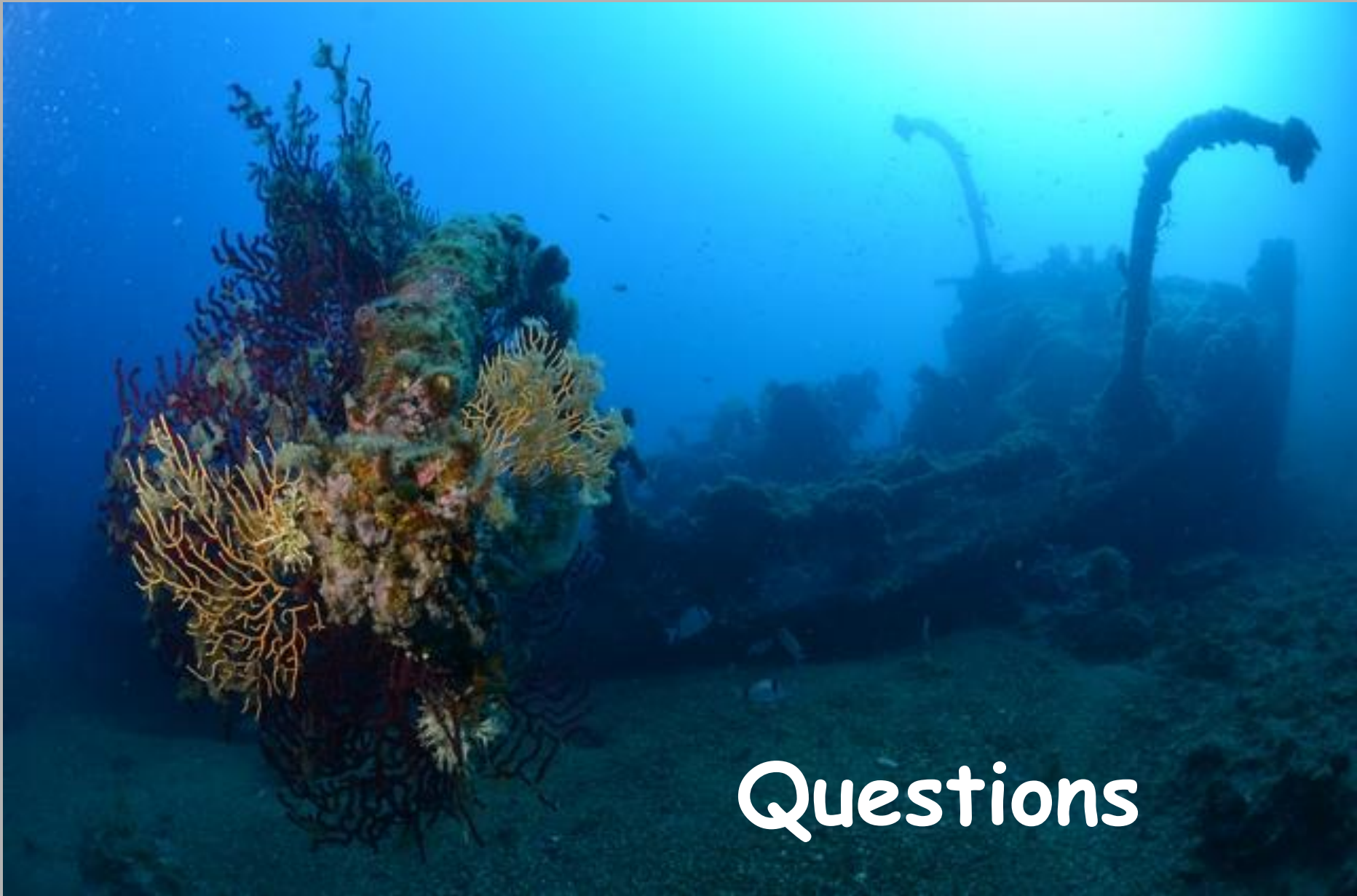

Questions